

APPLICATION

Water service gate valves comply with AS 1628 and are suitable for use in underground mains-meter services, as well as above ground civil, commercial and industrial installations.

TECHNICAL DATA

Standards:	AS 1628
Size Range:	DN 15 – 80
Pressure Range:	PN 25
Max Temperature:	180 deg C
Material:	DR Brass
Types:	Metal Seat
Ends:	F-BSP
Handle Options:	DI Handwheel, DR Brass T-Handle

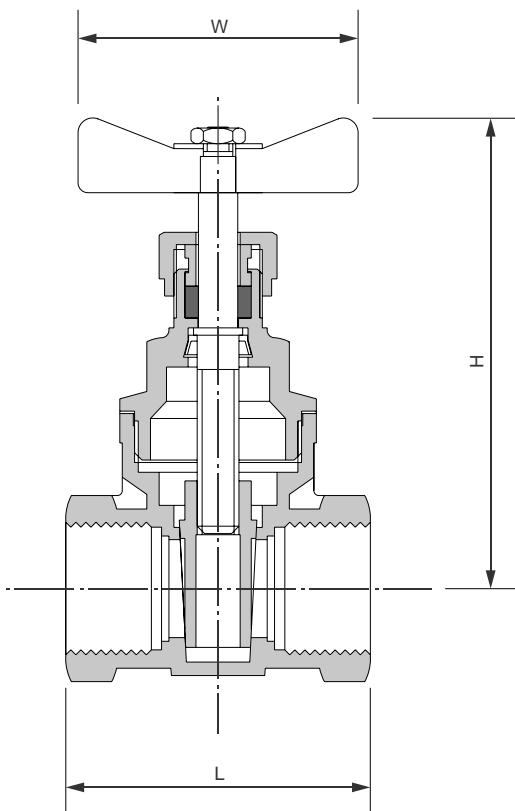

COMPONENTS

PART	MATERIAL
Body	DR Brass
Bonnet	DR Brass
Wedge	DR Brass
Stem	DR Brass
Packing	PTFE
Handwheel	Ductile Iron
T-Handle	DR Brass
Handwheel/Handle Retainer	Brass Nut

F/F BRASS GATE VALVE

Dia	Ends	L	H	W	Handwheel	T-Handle
15	15F / 15F	57	77	54	BVG15	BVG15T
20	20F / 20F	62	90	60	BVG20	BVG20T
25	25F / 25F	73	103	72	BVG25	BVG25T
32	32F / 32F	83	122	72	BVG32	BVG32T
40	40F / 40F	86	134	80	BVG40	BVG40T
50	50F / 50F	98	160	100	BVG50	BVG50T
65	65F / 65F	105	198	117	BVG65	BVG65T
80	80F / 80F	117	230	140	BVG80	BVG80T

CIVILPIPES PTY LTD

ABN 30 168 566 667
 2 Potassium St. Narangba Qld 4504
 PO Box 304, North Lakes Qld 4509



Web:
civilpipes.com.au



Telephone:
 +61 7 3053 3456



E-mail:
sales@civilpipes.com.au



WSGV_0324